



Monochrome CCD Camera

WAT-902H2 SUPREME WAT-902H3 SUPREME

Operation Manual

This Operation Manual covers safety, camera functions, installation and the correct operating procedure for the WAT-902H2/3 SUPREME. First, we ask you to read this Operation Manual thoroughly, then install and operate the WAT-902H2/3 SUPREME as advised. In addition, for future reference, we also advise safekeeping of this manual.

Please contact the distributor or dealer from which the WAT-902H2/3 SUPREME was purchased, if you do not understand the installation, operation or safety instructions laid out in this manual. Not understanding the contents of the Operation Manual sufficiently may cause damage to the camera.

Guide to the Safety Symbols

The definitions of the symbols used in this operation manual are:

Danger When you do not adhere to or take notice of the "Danger" sign, it may lead to a serious accident such as death or injury caused by fire or electric shock.

Warning When you do not adhere to or take notice of the "Warning" sign, it may cause severe damage such as a physical injury.

Caution When you do not adhere to or take notice of the "Caution" sign, it may incur injury and cause damage to peripheral objects in the immediate surroundings.

Cautions for Safety

WAT-902H2/3 SUPREME is designed to be used safely; however, if not used safely, it may lead to a physical accident caused by fire and electric shock. Therefore, please keep and read the "Cautions for Safety" below for protection against accidents.

Danger • Do not disassemble and/or modify the WAT-902H2/3 SUPREME.
• Do not operate the WAT-902H2/3 SUPREME with wet hands.

Warning • Use a stabilized power adaptor designed for DC+12V±10%, with a current capacity of more than 250mA for the WAT-902H2/3 SUPREME.
The recommended voltage is DC+12V±10%

• Do not expose the WAT-902H2/3 SUPREME to wetness or high moisture conditions.
The WAT-902H2/3 SUPREME is designed and approved for indoor use only. The WAT-902H2/3 SUPREME is not water-resistant or waterproof. If the location of the camera is outdoors or in an outdoor like environment, we recommend that you use an outdoor camera housing.

• Protect the WAT-902H2/3 SUPREME from condensation.
Keep the WAT-902H2/3 SUPREME dry at all times during storage and operation.

• Should the camera not work properly, switch off the power immediately. Then check the camera according to the "Problems and Trouble Shooting" section.

Caution • Avoid the striking of hard objects or dropping the WAT-902H2/3 SUPREME.
The WAT-902H2/3 SUPREME uses high quality electrical parts and precision components.

• Do not connect any power supply directly to the video out terminal of the unit.

Do not connect the WAT-902H2/3 SUPREME with any monitor using a video/power single transmission terminal. The WAT-902H2/3 SUPREME is not designed for use with this type of equipment. We also advise you to read the operation manual of the monitor you plan to use before any connections are made.

• Do not install the WAT-902H2/3 SUPREME in a position subject to direct sunlight.

Sunlight shining directly onto the WAT-902H2/3 SUPREME lens can cause damage to the CCD.

• Select a stable place for installation of the WAT-902H2/3 SUPREME.

Use a support of durable strength around an installation position on a ceiling or wall when a camera stand or tripod is used.

• Do not move the WAT-902H2/3 SUPREME with the cables connected.

Before moving the WAT-902H2/3 SUPREME, always remove the video cable and power cable from the rear of the camera first.

• Avoid using the WAT-902H2/3 SUPREME near any strong electromagnetic field.

After installing into main equipment, if the WAT-902H2/3 SUPREME is exposed to electromagnetic waves causing the monitored image to become distorted, we recommend the camera be shielded by appropriate protective casing.

Problems and Trouble Shooting

If any of the following problems occur when using the WAT-902H2/3 SUPREME,

- An optimal picture cannot be obtained, after checking that all the cables and connections are correctly in place
- Smoke or any unusual odor emerges from the WAT-902H2/3 SUPREME
- An object becomes embedded or a quantity of liquid seeps into the camera housing
- More than the recommended voltage or/and amperage has been applied to the WAT-902H2/3 SUPREME by mistake
- Anything unusual occurring to any equipment connected to the WAT-902H2/3 SUPREME.

Disconnect the camera immediately according to the following procedures:

- ① Switch off the main power supply to the camera.
- ② Remove the power and video cables connected to the WAT-902H2/3 SUPREME.
- ③ Contact the distributor or dealer from which the WAT-902H2/3 SUPREME was purchased.

About EMC

The WAT-902H2/3 SUPREME is in conformity with EMC test standards carried out by authorized organizations in Japan.

E I A FCC Part15 class B
CCIR EN61000-6-3/EN50130-4

Danger Do not modify the WAT-902H2/3 SUPREME. A modified camera may not conform to EMC test standards.

Contents

Using the contents figures below, check to make sure all parts are present before use.

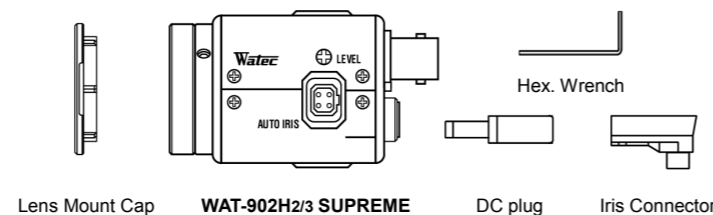

Description of Parts

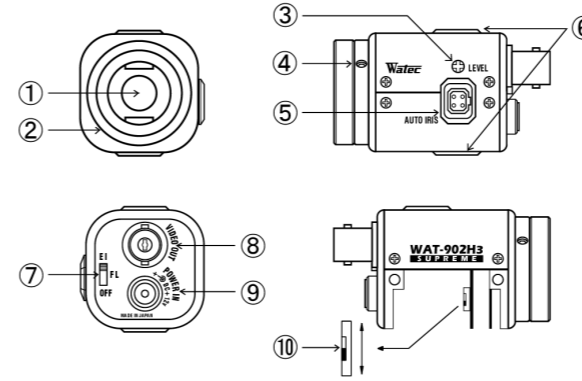

① CCD FRONT FACE

• The light receiving face of the CCD camera
(Dirt, water or oil deposits on the CCD will cause an unclear picture on the monitor. Attach the lens cap to protect the lens and CCD from contamination and damage.)

② LENS MOUNT

• Mount for the lens (Thread type)

③ IRIS LEVEL VOLUME

• By controlling the volume, the iris level of a DC iris lens can be adjusted.

④ FOCUSING ADJUSTMENT SCREWS

• There are 3 hex. adjustment screws each placed at intervals of 120° for fine focusing of the lens.

⑤ AUTO-IRIS SOCKET

• This socket is for a video or DC auto-iris lens cable connector.
(Video/DC: Auto selected by the camera)

⑥ TRIPOD MOUNTING SCREW HOLES

• Mounting holes for stands. The size of these threads are 1/4", 20 threads, 4.5±0.2mm, which is the same as any standard camera tripod (U1/4").

⑦ AE MODE CONTROL

• The switch for the shutter speed mode control according to the object being monitored

⑧ VIDEO OUT (BNC)

• The terminal for composite video signal output

⑨ POWER IN

• The terminal designed for connection with the DC-plug of the power adaptor

⑩ AGC SELECTION SWITCH

• Switch for setting AGC HI or LO

Power Supply

Use a stabilized power adaptor designed for DC+12V±10%, with a current capacity of more than 250mA.

Use the optional DC plug if the shape or polarity of the DC plug of the power adaptor to be used is not compatible with the camera (See the drawing on the right below).

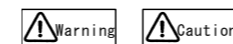

The wiring on the connector must be exact. Be careful not to touch the other terminal while wiring. Protect the wiring portion by using insulation tape after wiring. If the above care and attention is not adhered to, damage to the WAT-902H2/3 SUPREME and power adaptor may occur and may also cause fire.

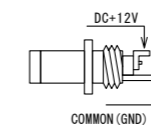

Auto-iris Lens

Before connecting the auto-iris lens, please make sure that the pin configuration is correct by confirming with the following table. If the configuration of your iris connector is different from the following, the plug and pins will need to be rewired.

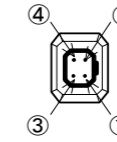

Pin No.	EIAJ Video Auto-iris Lens Arrangement	EIAJ DC Auto-iris Lens Arrangement
①	Power	Control -
②	Not used	Control +
③	Iris signals	Drive +
④	Common (GND)	Drive -

Set-up and Operation

- 1) Ensure that the power to the WAT-902H2/3 SUPREME and the peripheral equipment is turned off before making any connections.
- 2) Remove the lens mount cap from the WAT-902H2/3 SUPREME and attach the CS-mount lens. Use the optional C-mount adaptor (30CMA-R) when a C-mount lens is used.
- 3) Connect the iris control cable to ⑤ AUTO-IRIS SOCKET on the WAT-902H2/3 SUPREME when an auto-iris lens is being used.
- 4) Connect ⑧ VIDEO OUT on the WAT-902H2/3 SUPREME with the monitor, using a coaxial cable with 75Ω impedance, such as an RG-59 or an RG-6/U. Select a monitor with the same television system as the WAT-902H2/3 SUPREME: EIA or CCIR. A monitor with more than 600TV lines is recommended.
- 5) Insert the power plug of the power adaptor into ⑨ POWER IN on the back panel of the WAT-902H2/3 SUPREME. Confirm that the power adaptor is not connected to the power supply before insertion of the power plug into ⑨ POWER IN.
- 6) Turn on the power to the WAT-902H2/3 SUPREME, monitor and all other allied equipment. When a picture cannot be obtained on the monitor, or a problem occurs, check and follow the procedure mentioned in the [Problems and Trouble Shooting] section.
- 7) After following the procedure below and the picture is still out of focus, open the iris fully and loosen ④ FOCUSING ADJUSTMENT SCREWS with the hex. wrench and move the lens forwards until a clear picture is obtained.

Manual Lens	Adjust the focus and iris to the best position on the lens.
Video Auto-iris Lens	Adjust the focus on the lens.
DC Auto-iris Lens	Adjust the iris level on the camera, then adjust the focus on the lens. See below.

Iris Level Adjustment (for DC auto-iris lenses)

Adjust ③ IRIS LEVEL VOLUME placed on the side of the unit until an acceptable light level is attained. No change will occur if a video iris lens or manual iris lens is fitted.

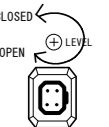

- 8) Set the shutter mode by ⑦ AE MODE CONTROL. (Shutter mode is set to EI upon shipment.)

AE Mode	Effect
EI	Automatically selects the shutter speed in the range between EIA: 1/60-1/100000 sec., CCIR: 1/50-1/100000 sec. according to the lighting condition.
FL	Reduces the flickering phenomena occurring on the monitor screen caused by fluorescent or mercury lamps.
OFF	Fixes the shutter speed to EIA: 1/60 sec., CCIR: 1/50 sec..

9) Set the AGC mode by ⑩AGC SELECTION SWITCH.
(AGC mode is set to HI upon shipment.)

Mode	Range	Effect
HI	5~50dB	• When minimum illumination is more important than the S/N ratio (Surveillance in a low light environment)
LO	5~32dB	• When SN ratio is more important than minimum illumination. • When adequate lighting is present or a stable lighting condition is available.

Options

To purchase these options, please contact the distributor or dealer from which you purchased the WAT-902H2/3 SUPREME.



C-mount Adaptor (30CMA-R)

This lens mount adaptor is used to convert a CS-mount to a C-mount.



Mini Stand (MS50)

A convenient stand for the WAT-902H2/3 SUPREME. With this stand, the camera can be adjusted to any desired angle.

关于电子信息产品污染控制标识

环境使用期限	名称	有害物质或元素					
		铅	镉	汞	六价铬	PBB	PBDE
	外壳	○	○	○	○	○	○
	电子零部件	×※1	○	○	○	○	○
	电路基板	○	○	○	○	○	○
	附件	○	○	○	○	○	○
	其它金属	×	○	○	○	○	○

○:表示该有害物质在该部件所有均质材料中的含量的在SJ/T 11363-2006规定的限量要求以下。
×:表示该有害物质至少在该部件的某一均质材料中的含量超出SJ/T 11363-2006规定的限量要求。
电源输入端子的铜合金中含有9%以下的铅。
※1:CCD的低熔点玻璃中含有600,000ppm的铅(WAT-902H2 SUPREME)。尚无制造代用品的技术。

瓦楞纸板	LDPE	LDPE	PP
外包装箱	包装袋	气帽	附件袋

※生产日期位于包装的上面

A	A	年	记号	月	记号
		2011	A	1	1
年	月	2012	B	10	A

Specifications

WAT-902H2 SUPREME

Model	WAT-902H2 SUPREME	
	EIA	CCIR
Pick-up Element	1/2 inch interline transfer CCD image sensor	
Unit Cell Size	8.4 μm(H) × 9.8 μm(V)	8.6 μm(H) × 8.3 μm(V)
Minimum Illumination	0.0003 lx. F1.4	
Power Consumption	1.98W (165mA)	

WAT-902H3 SUPREME

Model	WAT-902H3 SUPREME	
	EIA	CCIR
Pick-up Element	1/3 inch interline transfer CCD image sensor	
Unit Cell Size	6.35 μm(H) × 7.4 μm(V)	6.5 μm(H) × 6.25 μm(V)
Minimum Illumination	0.0005 lx. F1.4	
Power Consumption	1.86W (155mA)	

WAT-902H2 SUPREME / WAT-902H3 SUPREME

Model	WAT-902H2/3 SUPREME		
	EIA	CCIR	
Number of Total Pixels	811(H) × 508(V)	795(H) × 596(V)	
Number of Effective Pixels	768(H) × 494(V)	752(H) × 582(V)	
Sync. System	Internal		
Scanning System	2:1 interlace		
Video Output	Composite video, 1.0 V(p-p) 75 Ω (Unbalanced)		
Resolution (H)	More than 570TVL (Center)		
S/N	More than 46dB (AGC=5dB, γ=1.0)		
AE Mode	OFF	1/60 sec.	1/50 sec.
	FL	1/100 sec.	1/120 sec.
	EI	1/60-1/100000 sec.	1/50-1/100000 sec.
AGC	HI: 5-50dB / LO: 5-32dB		
Gamma Characteristics	γ ≒ 0.45		
Lens iris	Video / DC (EIAJ arrangement, Auto-select)		
Back Light Compensation	ON		
Power Supply	DC+12V ± 10%		
Operating Temperature	-10 - +40°C		
Operating Humidity	Less than 95% RH (Without condensation)		
Storage Temperature	-30 - +70°C		
Storage Humidity	Less than 95% RH (Without condensation)		
Lens Mount	CS-mount		
Size	35.5(W) × 36(H) × 63(L) (mm)		
Weight	Approx. 90g		

- Design and specifications are subject to change without notice.
- Watec is not responsible for any inconvenience or the attendant damages to the video and monitoring recording equipment caused by misuse, misoperation or improper wiring of our equipment.
- If for any reason the WAT-902H2/3 SUPREME does not work properly, or if you have any questions regarding installation or operation, please contact the distributor or dealer from which it was purchased.

Contact information

Watec Co., Ltd.

Add.: 254-2 Nihonkoku, Daihoji, Tsuruoka- Shi,
Yamagata-Ken, 997-0017 Japan
TEL: +81-235-23-4400 FAX: +81-235-23-4409
E-mail: info-o@watec.co.jp
URL: http://www.watec.co.jp