



Monochrome Board CCD Camera

WAT-902HB Series

Operation Manual

This Operation Manual covers safety, camera functions, installation and the correct operating procedure for the WAT-902HB series. First, we ask you to read this Operation Manual thoroughly, then install and operate the WAT-902HB series as advised. In addition, for future reference, we also advise safekeeping of this manual.

Please contact the distributor or dealer from which the WAT-902HB series was purchased, if you do not understand the installation, operation or safety instructions laid out in this manual. Not understanding the contents of the Operation Manual sufficiently may cause damage to the camera.

Guide to the Safety Symbols

The definitions of the symbols used in this operation manual are:

Danger When you do not adhere to or take notice of the "Danger" sign, it may lead to a serious accident such as death or injury caused by fire or electric shock.

Warning When you do not adhere to or take notice of the "Warning" sign, it may cause severe damage such as a physical injury.

Caution When you do not adhere to or take notice of the "Caution" sign, it may incur injury and cause damage to peripheral objects in the immediate surroundings.

Cautions for Safety

The WAT-902HB series is designed to be used safely; however, it may lead to a physical accident caused by fire and electric shock if not used correctly. Therefore, please keep and read the "Cautions for safety" below for protection against accidents.

Danger • Do not disassemble and/or modify the WAT-902HB series.
• Do not operate the WAT-902HB series with wet hands.

Warning • Use a stabilized power adaptor designed for DC+12V±10%, with a current capacity of more than 250mA for the WAT-902HB series.

The recommended voltage is DC+12V±10%

• Do not expose the WAT-902HB series to wetness or high moisture conditions.

The WAT-902HB series is designed and approved for indoor use only. The WAT-902HB series is not water-resistant or waterproof. If the location of the camera is outdoors or in an outdoor like environment, we recommend that you use an outdoor camera housing.

• Protect the WAT-902HB series from condensation.

Keep the WAT-902HB series dry at all times during storage and operation.

• Should the camera not work properly, switch off the power immediately. Then, check the camera according to the "Problems and Trouble shooting" section.

Caution • Avoid the striking of hard objects or dropping the WAT-902HB series.

The WAT-902HB series uses high quality electrical parts and precision components.

• Do not connect any power supply directly to the video out terminal of the unit.

Do not connect the WAT-902HB series with any monitor using a video/power single transmission terminal. The WAT-902HB series is not designed for use with this type of equipment. We also advise you to read the operation manual of the monitor you plan to use before any connections are made.

• Do not install the WAT-902HB series in a position subject to direct sunlight.

Sunlight shining directly onto the WAT-902HB series lens can cause damage to the CCD.

• Select a stable place for installation of the WAT-902HB series. Always fix the camera securely. See [Mounting Holes] section.

• Do not move the WAT-902HB series with the cables connected.

Before moving the WAT-902HB series, always remove the video cable and power cable from the camera first.

• Avoid using the WAT-WAT-902HB series near any strong electromagnetic field.

After installing into main equipment, if the WAT-902HB series is exposed to electromagnetic waves causing the monitored image to become distorted, we recommend the camera be shielded by appropriate protective casing.

Problems and Trouble Shooting

If any of the following problems occur when using the WAT-902HB series,

- An optimal picture cannot be obtained, after checking that all the cables and connections are correctly in place
- Smoke or any unusual odor emerges from the WAT-902HB series
- An object becomes embedded or a quantity of liquid seeps into the camera
- More than the recommended voltage or/and amperage has been applied to the WAT-902HB series by mistake
- Anything unusual occurring to any equipment connected to the WAT-902HB series.

Disconnect the camera immediately according to the following procedures:

- ① Switch off the main power supply to the camera.
- ② Remove the power and video cables connected to the WAT-902HB series.
- ③ Contact the distributor or dealer from which the WAT-902HB series was purchased.

Contents

Using the contents figures below, check to make sure all parts are present before use.

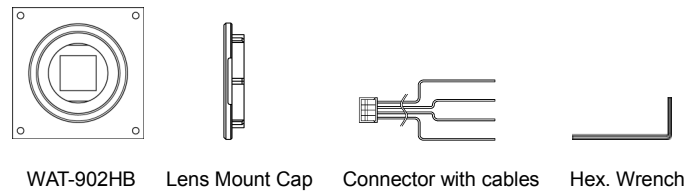

Description of Parts

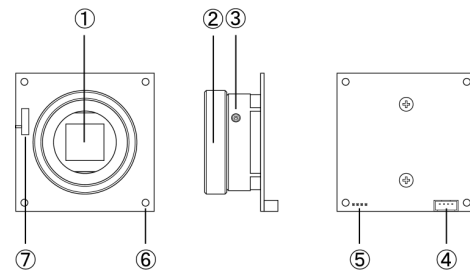

- ① LENS FRONT FACE
 - The light receiving face of the lens (Dirt, water or oil deposits on the lens will cause an unclear picture on the monitor. Attach the lens cap to protect the lens from contamination and damage.)
- ② LENS MOUNT
 - Mount for the lens (Thread type)
- ③ FINE FOCUS ADJUSTING SCREWS
 - There are 3 hex. adjustment screws each placed at intervals of 120° for fine focusing of the lens.
- ④ POWER IN/VIDEO OUT
 - The terminal for power input and video signal output. Use the attached connector with cables for this purpose.
- ⑤ TERMINAL FOR AUTO-IRIS LENS (VIDEO CONTROL)
 - The terminal for a Video-driven auto-iris lens. Do not connect a DC-driven auto-iris lens to this terminal.
- ⑥ MOUNTING HOLES
 - Holes for mounting the camera.
- ⑦ AGC SELECTION SWITCH
 - Switch for setting AGC HI or LO

Power Supply and Wiring

Use a stabilized power adaptor designed for DC+12V±10%, with a current capacity of more than 250mA.

The wiring on the connector must be exact. Be careful not to touch the other terminals while wiring. Protect the wired portion by using insulation tape. If the above care and attention is not adhered to, damage to the WAT-902HB series and power adaptor may occur and may also cause fire.

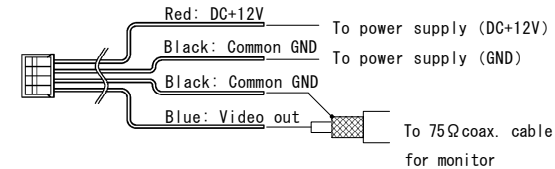

Mounting Holes

As shown in the figure on the right. The WAT-902HB series provides four mounting holes(φ2.2mm), one in each corner of the circuit board. Fix the unit securely using M2 screws. Once the board is secured proceed with the following steps below.

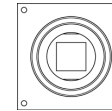

Set-up and Operation

- 1) Ensure that the power to the WAT-902HB series and the peripheral equipment is turned off before making any connections.
- 2) Remove the lens mount cap from the WAT-902HB series.
- 3) When an auto iris lens is being used, connect the cable to ⑤ TERMINAL FOR AUTO-IRIS LENS.
 - ※ Do not connect a DC control iris lens to this camera.
- 4) Connect the attached cable to ④ POWER IN/VIDEO OUT. See the [Power Supply and Wiring] section.
- 5) Connect a coaxial cable with 75Ω impedance, such as an RG-58/U or an RG-6/U to the monitor. Select a monitor with the same television system as the WAT-902HB series: EIA or CCIR. A monitor with more than 600TV lines is recommended.
- 6) Turn on the power to the WAT-902HB series, monitor and all other allied equipment. When a picture cannot be obtained on the monitor, check and follow the procedure mentioned in the [Problems and Trouble Shooting] section.
- 7) After following the procedure below and the picture is still out of focus, open the iris fully and loosen ③ FOCUSING ADJUSTMENT SCREWS with the hex. wrench and move the lens forwards until a clear picture is obtained.

Manual Lens	Adjust the focus and iris to the best position on the lens.
Video Auto-iris Lens	Adjust the focus on the lens.

- 8) Set the AGC mode by ⑦ AGC SELECTION SWITCH.

Mode	Range	Effect
HI	5~50dB	• When minimum illumination is more important than the SN ratio (Surveillance in a low light environment)
LO	5~32dB	• When SN ratio is more important than minimum illumination. • When adequate lighting is present or a stable lighting condition is available.

Function Setting

There are various function settings on the circuit board of the WAT-902HB series. To change the function preferences re-solder the settings to your requirement.

Electronic Iris

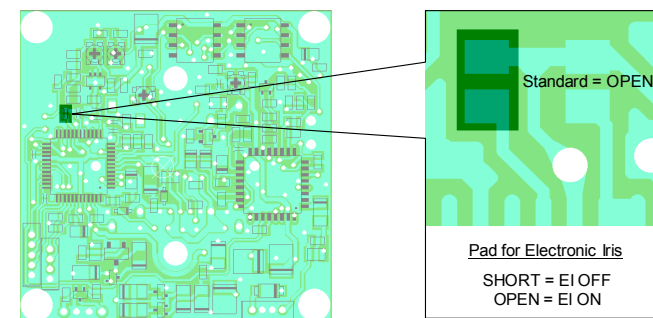

Gamma Correction

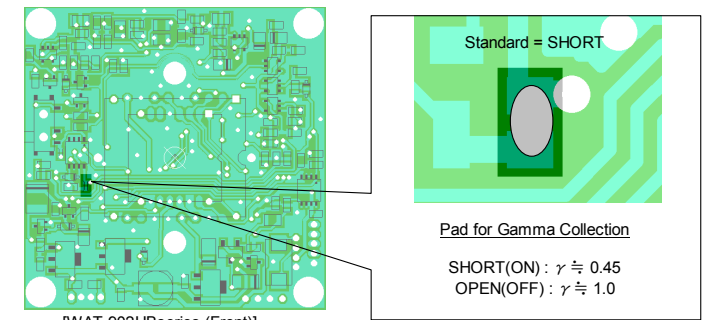

AGC

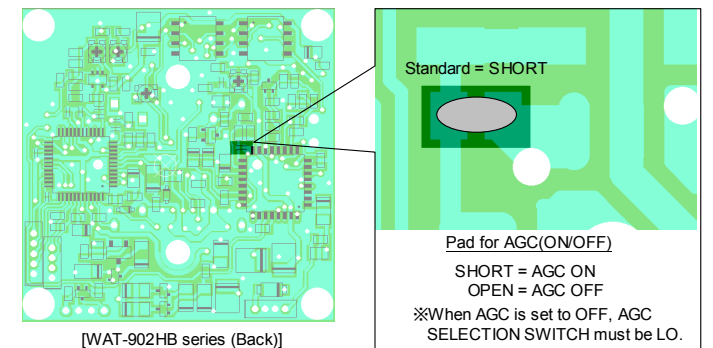

Back Light Compensation

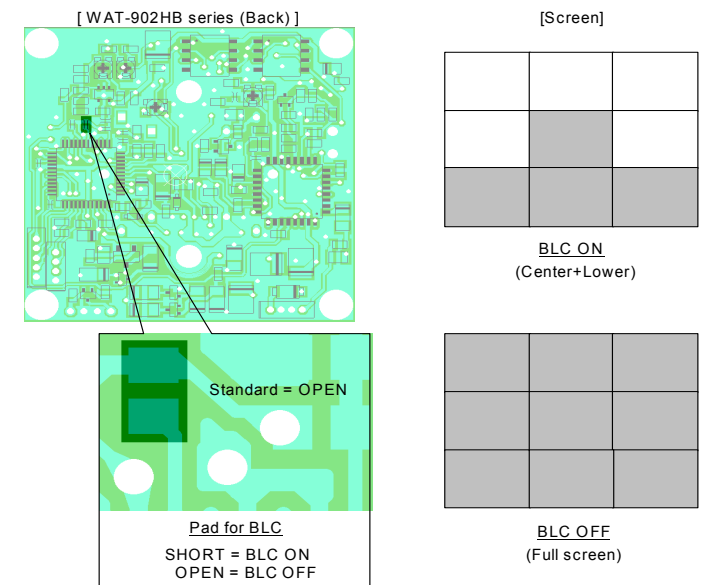

Electronic Shutter

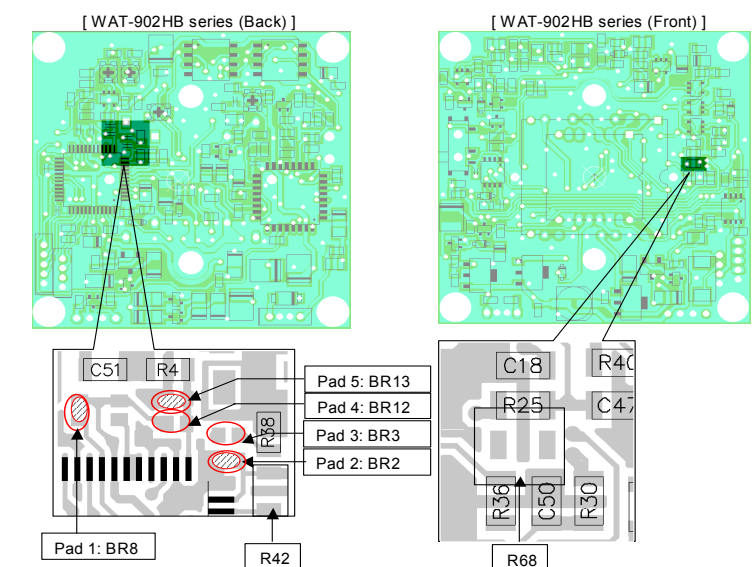

※ When the function is returned to electronic iris mode, be sure to reinstall the resistor. Therefore, we recommend safe keeping of the resistor.

• Pad for electronic shutter function:

[Unit: sec.]

	RES	RES	Pad 1	Pad 2	Pad 3	Pad 4	Pad 5
	R68	R42	BR8	BR2	BR3	BR12	BR13
EI (EIA: 1/60~100000) (CCIR: 1/50~100000)	MOUNT	MOUNT	OPEN	OPEN	OPEN	OPEN	OPEN
OFF (EIA: 1/60) (CCIR: 1/50)							
FL (EIA: 1/100) (CCIR: 1/120)	NO MOUNT	NO MOUNT	SHORT	OPEN	SHORT	SHORT	OPEN
1/250				OPEN	OPEN	SHORT	OPEN
1/500				OPEN	SHORT	OPEN	SHORT
1/1000				OPEN	OPEN	OPEN	SHORT
1/2000				SHORT	SHORT	SHORT	OPEN
1/5000				SHORT	OPEN	SHORT	OPEN
1/10000				SHORT	SHORT	OPEN	SHORT
1/100000				SHORT	OPEN	OPEN	SHORT

※The default setting is EI.

■Auto Iris

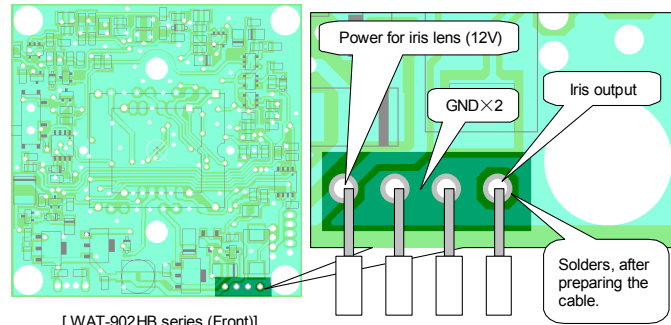

[WAT-902HB series (Front)]

※WAT-902HB series is designed for a video control auto iris lens. DC controlled auto iris lenses are not supported for this camera.

※Cut the cable close to the connector, strip the wires back and then solder to the appropriate terminals of the WAT-902HB series.

Option

To purchase these options, please contact the distributor or dealer from which you purchased the WAT-902HB series.



C-mount Adaptor (30CMA-R)

This lens mount adaptor is used to convert a CS-mount to a C-mount.

Specifications

WAT-902HB2/2S

Model	WAT-902HB2/2S	
	EIA	CCIR
Pick-up Element	1/2 inch interline transfer CCD image sensor	
Unit Cell Size	8.4 μm(H) × 9.8 μm(V)	8.6 μm(H) × 8.3 μm(V)
Minimum Illumination	0.0009 lx. F1.4 (2)	0.0003 lx. F1.4 (2S)

WAT-902HB3/3S

Model	WAT-902HB3/3S	
	EIA	CCIR
Pick-up Element	1/3 inch interline transfer CCD image sensor	
Unit Cell Size	6.35 μm(H) × 7.4 μm(V)	6.5 μm(H) × 6.25 μm(V)
Minimum Illumination	0.0012 lx. F1.4 (3)	0.0006 lx. F1.4 (3S)

WAT-902HB2/2S/3/3S

System	EIA	CCIR
Number of Total Pixels	811(H) × 508(V)	795(H) × 596(V)
Number of Effective Pixels	768(H) × 494(V)	752(H) × 582(V)
Sync. System	Internal	
Scanning System	2:1 interlace	
Video Output	Composite video, 1.0 V(p-p) 75 Ω (Unbalanced)	
Resolution (H)	More than 570TVL (Center)	
S/N	More than 50dB (AGC=5dB, γ=1.0)	
AE mode	OFF	1/60sec. / 1/50sec.
	FL	1/100sec. / 1/120sec.
	ES	1/250, 1/500, 1/1000, 1/2000, 1/5000, 1/10000, 1/100000 sec.
	EI	1/60-1/100000 sec. / 1/50-1/100000 sec.
AGC	ON	HI: 5-50dB / LO: 5-32dB
	OFF	5dB
Gamma Characteristics	γ ≈ 0.45(ON) / γ = 1.0(OFF)	
Lens iris	Video (Watec original arrangement)	
Back Light Compensation	ON / OFF	
Power Supply	DC+12V±10%	
Power Consumption	1.92W (160mA)	
Operating Temperature	-10 ~ +40°C (Without condensation)	
Operating Humidity	Less than 95% RH	
Storage Temperature	-30 ~ +70°C (Without condensation)	
Storage Humidity	Less than 95% RH	
Lens Mount	CS-mount	
Size	40(W) × 40(H) × 21(L) (mm)	
Weight	Approx. 30g	

- Design and specifications are subject to change without notice.
- Watec is not responsible for any inconvenience or the attendant damages to the video and monitoring recording equipment caused by misuse, mis-operation or improper wiring of our equipment.
- If for any reason the WAT-902HB series does not work properly, or if you have any questions regarding installation or operation, please contact the distributor or dealer from which it was purchased.

Contact information

Watec Watec Co., Ltd.

Add.: 254-2 Nihonkoku, Daihoji, Tsuruoka- Shi,
Yamagata-Ken, 997-0017 Japan
TEL: +81-235-23-4400 FAX: +81-235-23-4409
Email: info-o@watec.co.jp
URL: http://www.watec.net