

This Operation Manual covers safety, camera functions, installation and the correct operating procedure for the WAT-502B. First, we ask you to read this Operation Manual thoroughly, then install and operate the WAT-502B as advised. In addition, for future reference, we also advise safe keeping of this manual.

Please contact the distributor or dealer from which the WAT-502B was purchased, if you do not understand the installation, operation or safety instructions laid out in this manual. Not understanding the contents of the Operation Manual sufficiently may cause damage to the camera.

Guide to the Safety Symbols

The definitions of the symbols used in this operation manual are:

When you do not adhere to or take notice of the "Danger" sign, it may lead to a serious accident such as death or injury caused by fire or electric shock.

When you do not adhere to or take notice of the "Warning" sign, it may cause severe damage such as a physical injury.

When you do not adhere to or take notice of the "Caution" sign, it may incur injury and cause damage to peripheral objects in the immediate surroundings.

Cautions for Safety

The WAT-502B is designed to be used safely; however, it may lead to a physical accident caused by fire and electric shock if not used correctly. Therefore, please keep and read the "Cautions for Safety" for protection against accidents.

- Do not disassemble and/or modify the WAT-502B.
- Do not operate the WAT-502B with wet hands.

- Use only the AD502-120/230 or equivalent power adaptor for the WAT-502B.

The recommended voltage is DC+9V±10%

- Do not expose the WAT-502B to wetness or high moisture conditions.

The WAT-502B is designed and approved for indoor use only. The WAT-502B is not water-resistant or waterproof. If the location of the camera is outdoors or in an outdoor like environment, we recommend that you use an outdoor camera housing.

- Protect the WAT-502B from condensation.

Keep the WAT-502B dry at all times during storage and operation.

- Should the camera not work properly, switch off the power immediately. Then check the camera according to the "Problems and Trouble Shooting" section.

- Avoid the striking of hard objects or dropping the WAT-502B.

The WAT-502B uses high quality electrical parts and precision components.

- Do not connect any power supply directly to the video out terminal of the unit.

Do not connect the WAT-502B with any monitor using a video/power single transmission terminal. The WAT-502B is not designed for use with this type of equipment. We also advise you to read the operation manual of the monitor you plan to use before any connections are made.

- Do not install the WAT-502B in a position subject to direct sunlight.

Sunlight shining directly onto the WAT-502B lens can cause damage to the CCD.

- Select a stable place for installation of the WAT-502B.

Use a support of durable strength around an installation position on a ceiling or wall when a camera stand or tripod is used.

- Do not move the WAT-502B with the cables connected. Before moving the WAT-502B, always remove the video cable and power cable from the rear of the camera first.

- Avoid using the WAT-502B near any strong electromagnetic field.

After installing into main equipment, if the WAT-502B is exposed to electromagnetic waves causing the monitored image to become distorted, we recommend the camera be shielded by appropriate protective casing.

Problems and Trouble Shooting

If any of the following problems occur when using the WAT-502B,

- An optimal picture cannot be obtained, after checking that all the cables and connections are correctly in place
- Smoke or any unusual odor emerges from the WAT-502B.
- An object becomes embedded or a quantity of liquid seeps into the camera housing
- More than the recommended voltage or/and amperage has been applied to the WAT-502B by mistake
- Anything unusual occurring to any equipment connected to the WAT-502B.

Disconnect the camera immediately according to the following procedures:

- Switch off the main power supply to the camera.
- Remove the power and video cables connected to the WAT-502B.
- Contact the distributor or dealer from which the WAT-502B was purchased.

About EMC

The WAT-502B is in conformity with EMC test standards carried out by authorized organizations in Japan.

E I A FCC Part15 class B
CCIR EN61000-6-3/EN50130-4

- Do not modify the 502B. A modified camera may not conform to EMC test standards.

Contents

Using the contents figures below, check to make sure all parts are present before use.

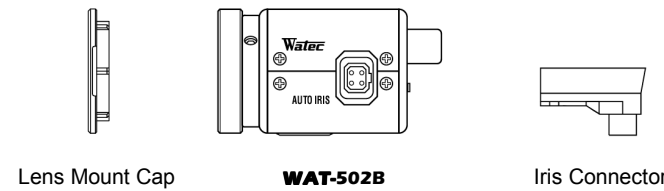

Description of Parts

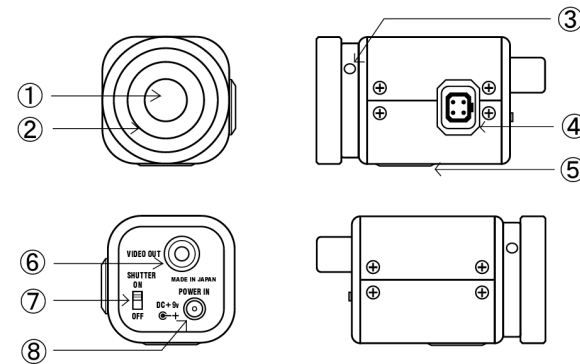

①CCD FRONT FACE

- The light receiving face of the CCD camera (Dirt, water or oil deposits on the CCD will cause an unclear picture on the monitor. Attach the lens cap to protect the lens and CCD from contamination and damage.)

②LENS MOUNT

- Mount for the lens (Thread type)

③FOCUSING ADJUSTMENT SCREWS

- There are 3 hex. adjustment screws each placed at intervals of 120° for fine focusing of the lens.

④AUTO-IRIS SOCKET

- This socket is for a video auto-iris lens.
 - For DC iris lenses, see the section below

⑤TRIPOD MOUNTING SCREW HOLE

- Mounting hole for stands. The size of the thread is 1/4", 20 threads, 4.5 ±0.2mm, which is the same as any standard camera tripod (U1/4").

⑥VIDEO OUT (BNC)

- The terminal for composite video signal output

⑦AE MODE CONTROL

- The switch for the shutter speed mode control according to the object being monitored

⑧POWER IN

- The terminal designed for connection with the DC-plug of the power adaptor

Power Supply

If any other power adaptor besides the AD502-120/230 is used, please use a stabilized power adaptor designed for DC+9V±10%, with a current capacity of more than 200mA.

Use the additional DC plug if the shape or polarity of the DC plug of the power adaptor to be used is not compatible with the camera (See the drawing on the right below).

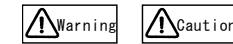

The wiring on the connector must be exact.

Be careful not to touch the other terminal while wiring. Protect the wiring portion by using insulation tape after wiring. If the above care and attention is not adhered to, damage to the WAT-502B and power adaptor may occur and may also cause fire.

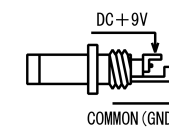

Auto-iris Lens

Before connecting the auto-iris lens, please make sure that the pin configuration is correct by checking with the following figure below. If the configuration of your iris connector is different from the following, the plug and pins will need to be rewired.

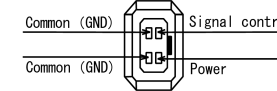

※This auto-iris terminal is only for video auto-iris lenses. If a DC auto-iris lens is required, you must use the optional DC iris cable (HC-01).

Set-up and Operation

- Ensure that the power to the WAT-502B and the peripheral equipment is turned off before making any connections.
- Remove the lens mount cap from the WAT-502B and attach the CS-mount lens. Use the optional C-mount adaptor (30CMA-R) when a C-mount lens is used.
- Connect the iris cable to ④AUTO-IRIS SOCKET on the WAT-502B when an auto-iris lens is being used.
- Connect ⑥VIDEO OUT on the WAT-502B with the monitor, using a coaxial cable with 75Ω impedance, such as an RG-58/U or an RG-6/U. Select a monitor with the same television system as the WAT-502B: EIA or CCIR. A monitor with more than 500TV lines is recommended.
- Insert the power plug of the power adaptor into ⑧POWER IN on the back panel of the WAT-502B. Confirm that the power adaptor is not connected to the power supply before insertion of the power plug into ⑧POWER IN.
- Turn on the power to the WAT-502B, monitor and all other allied equipment. When a picture cannot be obtained on the monitor, or a problem occurs, check and follow the procedure mentioned in the 【Problems and Trouble Shooting】 section.
- After following the procedure below and the picture is still out of focus, open the iris fully and loosen ③FOCUSING ADJUSTMENT SCREWS and move the lens forwards until a clear picture is obtained.

Manual Lens	Adjust the focus and iris to the best position on the lens.
Video Auto-iris Lens	Adjust the focus on the lens.
DC Auto-iris Lens	Connect the DC Auto-iris lens using optional DC iris cable (HC-01) to ④AUTO-IRIS SOCKET, then, adjust the iris level and the focus to the best position.

- Set the shutter mode by ⑦AE MODE CONTROL. When shutter mode is OFF, the shutter speed is set to EIA1/60, CCIR1/50. When shutter mode is ON, the shutter speed is set to EIA1/60-1/100000, CCIR1/50-1/100000.

Options

To purchase these options, please contact the distributor or dealer from which you purchased the WAT-502B.



AC Adaptor (AD502-120/230)

The recommended AC adaptor, for the WAT-502B for a constant and stable power supply.



C-mount Adaptor (30CMA-R)

This mount adaptor is used to convert a CS-mount into a C-mount.



DC Iris Cable (HC-01)

The cable for connecting a DC iris lenses to a camera. (includes iris control)

Specifications

Model	WAT-502B (EIA)	WAT-502B (CCIR)
Pick-up element	1/3 inch interline transfer CCD image sensor	
Number of total Pixels	537(H) × 505(V)	537(H) × 597(V)
Number of effective pixels	510(H) × 492(V)	500(H) × 582(V)
Unit cell size	9.6 μm(H) × 7.5 μm(V)	9.8 μm(H) × 6.3 μm(V)
Sync. system	Internal	
Scanning system	2:1 interlace	
Video output	Composite video, 1.0 V(p-p) 75Ω (Unbalanced)	
Resolution (H)	More than 400TVL (Center)	
Minimum illumination	0.003 lx. F1.4	
S/N	More than 50dB (AGC=5dB, γ=1.0)	
AE mode	OFF	1/60 sec.
	EI	1/60-1/100000 sec.
AGC	5-32dB	
Gamma characteristics	γ ≈ 0.45	
Lens iris	Video (Watec original arrangement)	
Power supply	DC+9V ± 10%	
Power consumption	1.13W (125mA)	
Operating temperature	-10 - +40°C (Without condensation)	
Operating humidity	Less than 95% RH	
Storage temperature	-30 - +70°C (Without condensation)	
Storage humidity	Less than 95% RH	
Lens mount	CS-mount	
Size	31.5(W) × 30.5(H) × 54(L) (mm)	
Weight	Approx. 65g	

- Design and specifications are subject to change without notice.
- Watec is not responsible for any inconvenience or the attendant damages to the video and monitoring recording equipment caused by misuse, mis-operation or improper wiring of our equipment.
- If for any reason the WAT-502B does not work properly, or if you have any questions regarding installation or operation, please contact the distributor or dealer from which it was purchased.

Contact information



Addr.: 254-2 Nihonkoku, Daihoji, Tsuruoka- Shi, Yamagata-Ken, 997-0017 Japan
TEL: +81-235-23-4400 FAX: +81-235-23-4409
Email: info-o@watec.co.jp
URL: http://www.watec.net