

Watec

902H2/H3 SUPREME



SPECIFICATIONS

Model	WAT-902H2 SUPREME (EIA)	WAT-902H2 SUPREME (CCIR)
Pick-up element	1/2" interline transfer CCD image sensor	
Number of total pixels	811(H) × 508(V)	795(H) × 596(V)
Number of effective pixel	768(H) × 494(V)	752(H) × 582(V)
Unit cell size	8.4μm (H) × 9.8μm (V)	8.6μm (H) × 8.3μm (V)
Shutter speeds	EI: 1/60 sec. - 1/100,000 sec. FL: 1/100 sec. OFF: 1/60 sec.	EI: 1/50 sec. - 1/100,000 sec. FL: 1/120 sec. FL: 1/50 sec.
Minimum illumination	0.0003 lx F1.4 (AGC HI)	

Model	WAT-902H3 SUPREME (EIA)	WAT-902H3 SUPREME (CCIR)
Pick-up element	1/3" interline transfer CCD image sensor	
Number of total pixels	811(H) × 508(V)	795(H) × 596(V)
Number of effective pixel	768(H) × 494(V)	752(H) × 582(V)
Unit cell size	6.35μm (H) × 7.40μm (V)	6.50μm (H) × 6.25μm (V)
Shutter speeds	EI: 1/60 sec. - 1/100,000 sec. FL: 1/100 sec. OFF: 1/60 sec.	EI: 1/50 sec. - 1/100,000 sec. FL: 1/120 sec. FL: 1/50 sec.
Minimum illumination	0.0005 lx F1.4 (AGC HI)	

Common specifications	
Synchronizing system	Internal sync.
Video output	1Vp-p, 75ohms, unbalanced
Resolution (H)	570TVL (Center)
S/N ratio	46dB (AGC OFF)
AGC	HI: 5-50dB, LO: 5-32dB
Back light compensation	ON (Center + lower)
Gamma correction	0.45
Power supply	DC12V±10%
Current	160mA
Operating temperature	-10°C - +40°C
Storage temperature	-30°C - +70°C
Dimensions(W×H×L)	35.5 × 36 × 63 (mm)
Weight	90g

*Design and specifications are subject to change without notice.

DIMENSIONS (mm)

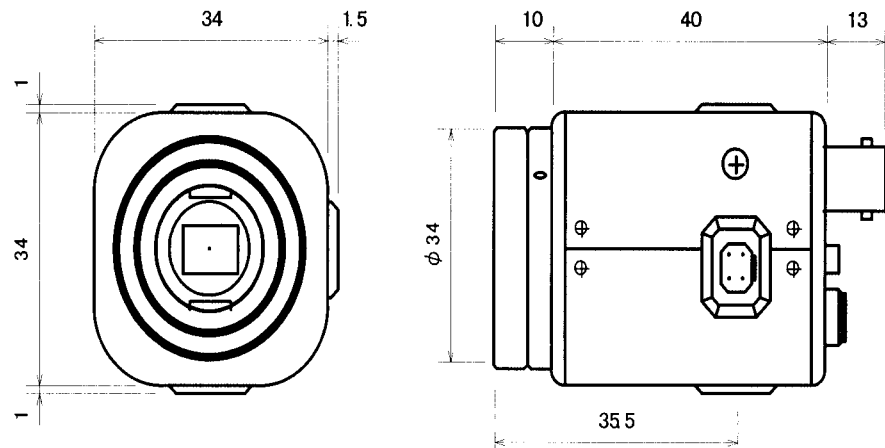

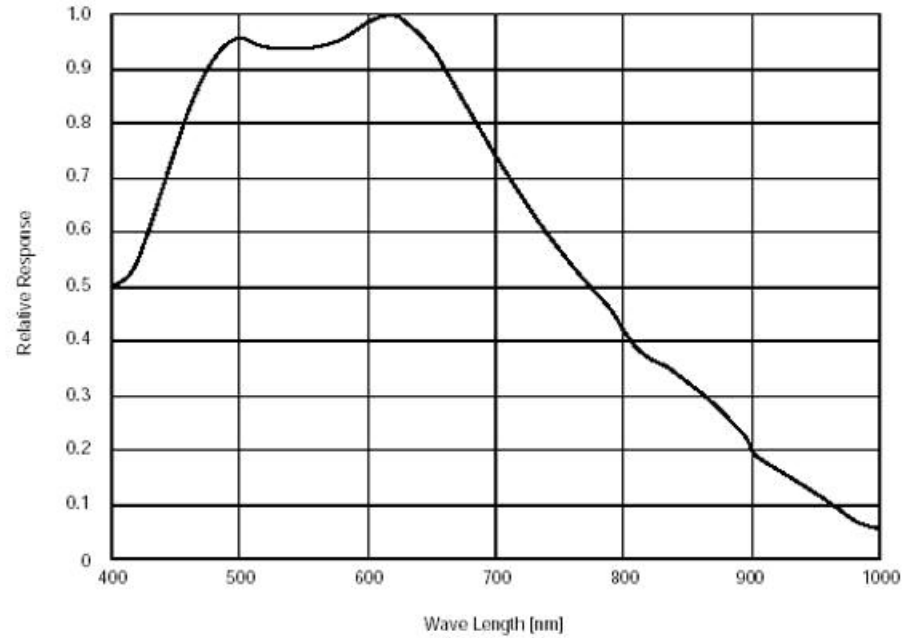

WAT-902H2 WAT-902H3
SUPREME SUPREME**Operation Manual**

This Operation Manual covers safety, camera functions, installation and correct operating procedure for the WAT-902H2/3 SUPREME. First, we ask you to read the manual thoroughly, then install and operate the WAT-902H2/3 SUPREME as advised. In addition, for future reference, we also advise safekeeping of this manual.

Please contact the distributor or dealer from which the WAT-902H2/3 SUPREME was purchased, if you do not understand the installation, operation, or safety instructions laid out in this manual. Not understanding the contents of the Operation Manual sufficiently may cause damage to the camera.

Cautions for Safety

The WAT-902H2/3 SUPREME is designed to be used safely. However, electrical goods may lead to physical accident caused by fire and electric shock if not used correctly. Therefore, please keep and read the "Cautions for Safety" for protection against accidents.



- Do not disassemble and/or modify the camera.
- Do not operate the camera with wet hands.



- Use only the AD-901 or equivalent power adaptor for the camera.

The recommended voltage is DC+12V ± 10%.

- Do not expose the camera to wetness or high moisture conditions.

The camera is designed and approved for indoor use only. This camera is not water-resistant or waterproof. If the location of the camera is an outdoor or in an outdoor-like environment, we recommend you use an outdoor camera housing.

- Protect the camera from condensation.

Keep the camera dry at all times during storage and operation.

- Should the camera not work properly, switch off the power immediately.

Please check the camera according to the "Problems and Trouble shooting" section.



- Avoid the striking of hard objects or dropping the camera.

The camera uses high quality electrical parts and precision components.

- Do not connect any power supply directly to the VIDEO OUT terminal of the unit.

Do not connect the camera with any monitor using a video/power single transmission terminal. This camera is not designed for use with this type of equipment. We also advise you to read the operation manual of the monitor you plan to use before any connections are made.

- Do not install the camera in a position subject to direct sunlight.

Sunlight shining directly onto the camera lens can cause damage to the CCD.

- Select a stable place for installation of the camera.

Use a support of durable strength around an installation position on a ceiling or wall when a camera stand or a stable tripod is used.

- Do not move the camera with the cables connected.

Before moving the camera, always remove the video cable(s), and power cable from the rear of the camera first.

- Avoid using the cameras near any strong electro-magnetic field.

Avoid emission sources of electromagnetic waves when the camera is installed into main equipment.

Guide to the Safety Symbols

The meanings of the symbols used in this Operation Manual are:



When you do not adhere to or take notice of the "Danger" sign, it may lead to serious accident such as death or injury caused by fire or electric shock.



When you do not adhere to or take notice of the "Warning" sign, it may cause severe damage such as a physical injury.



When you do not adhere to or take notice of the "Caution" sign, it may incur injury and cause damage to peripheral objects in the immediate surroundings.

About EMC

The camera is in conformity with EMC test standards carried out by an authorized organization in Japan.



Do not modify the camera. Modification to the camera is dangerous, and in addition, the camera may not conform to EMS test standards.

Problems and Trouble Shooting

If any of the following problems occur when using the camera:

- An optimal picture cannot be obtained after checking all the cables and connections are correctly in place.
- Smoke or any unusual odor emerges from the camera.
- An object becomes embedded or a quantity of liquid seeps into the camera housing.
- More than the recommended voltage or/and amperage has been applied to the camera by mistake.
- Anything unusual occurring to any equipment connected to the camera.

Disconnect the camera immediately according to the following procedure:

Switch off the main power supply to the camera.

Remove the power and video cables connected to the camera. Contact the distributor or dealer from which the camera was purchased.

The following phenomenon is not camera malfunction:

The picture on the monitor flickers when the camera is used under fluorescent and mercury lighting, which is called the "flicker" phenomenon. The flickering can be reduced by "FL (flickerless)" on the AE mode switch on the back panel.

Contents

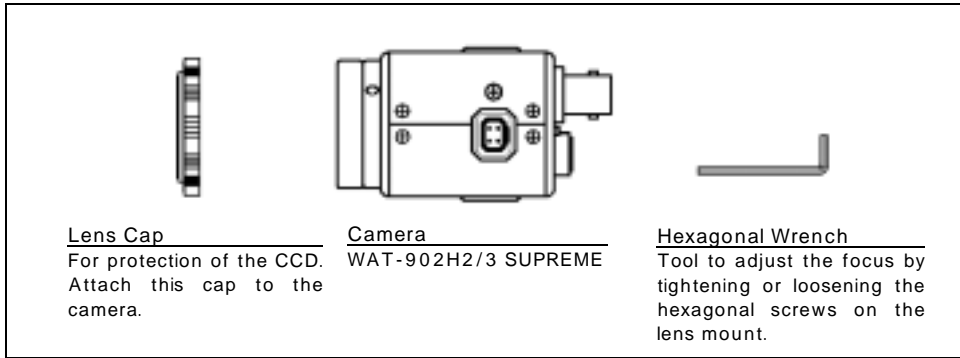

Description of Camera Parts & Functions

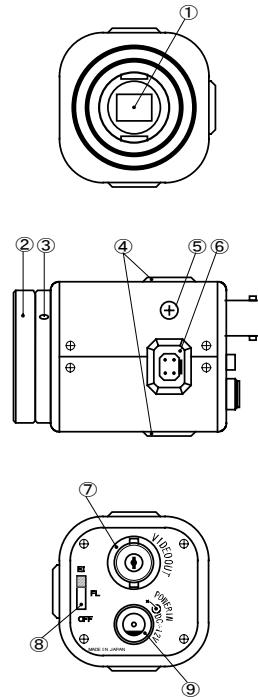

CCD FRONT FACE

- Dirt, water or oil deposits on the CCD will cause an unclear picture on the monitor.
- Attach the lens cap to protect the lens and the CCD from contamination and damage.

LENS MOUNT

- Mount for the lens (Thread type)

HEX. FOCUSING ADJUSTMENT SCREWS

- There are 3 screws each placed at intervals of 120°

TRIPOT MOUNTING SCREW HOLES

- The size of these threads are 1/4", 20 threads, 4.5 ± 0.2mm, which is the same as any standard camera tripod (U1/4").

IRIS LEVEL VOLUME

- By controlling the volume, the iris level of the DC iris lens can be adjusted.

AUTO-IRIS SOCKET

- The function is compatible for both video and DC driven iris lenses. The switching function is automatic and does not need setting manually.

VIDEO OUT (BNC)

- The terminal for composite video signal output

EI / FL / OFF SELECTION SWITCH

- "EI" is selected upon shipment.
- For detailed information, please see "Set-up and Operation" No. 4.

POWER IN

- The terminal designed for connection with a DC-plug from an appropriate power supply.
- The optional power adaptor, AD-901(DC+12V, 250mA), is recommended for use with this camera.

Preparation for Set-up

Recommended Lens

- For the WAT-902H2 SUPREME, CS-mount lenses for a 1/2" CCD camera is recommended.
- For the WAT-902H3 SUPREME, CS-mount lenses for a 1/3" CCD camera is recommended. (For a more effective picture, use an IR lens.)

Applicable Auto-iris Lens

- The camera automatically recognises the type of lens attached. Applicable auto-iris lenses are:
EIAJ video auto-iris lenses EIAJ DC auto-iris lenses

Wiring for Auto-iris Connectors



Pin No.	EIAJ Video Auto-iris Lens Arrangement	EIAJ DC Auto-iris Lens Arrangement
	Power	Control -
	Not Used	Control +
	Iris Signals	Drive +
	Common (GND)	Drive -



Before connecting the auto-iris lens, please make sure that the pin configuration is correct by confirming with the above table. If the configuration of your iris connector is different from the above, the plug and pins will need to be rewired.

Applicable AC Adaptors

- If any other power adaptor besides the AD-901 is used, please use a stabilized power adaptor designed for DC+12V ± 10%, with a current capacity of more than 250mA.
- Use the optional DC plug if the shape or polarity of the DC plug of the power adaptor to be used is not compatible with the camera, see the drawing on the right. Be careful not to touch any other terminal while wiring.

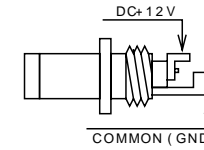

If the above-mentioned care and attention are not adhered to, it may cause an electrical fault.

Attaching a Lens

- Take off the lens cap attached to the camera, then screw on the lens.
- If an auto-iris lens is used, please confirm the lens specification, and connect the auto-iris control cable to the AUTO-IRIS SOCKET.

Set-up and Operation

Connection to Peripheral Equipment

1. Make sure that all the power to the camera and the peripheral equipment is turned off.
2. Connect ⑦ VIDEO OUT to the monitor using a cable with 75Ω impedance (for example, an RG-59 (TG-140/U, 3C-2V) or an RG-6A (5C-2V)).
3. Turn the camera, monitor, and any other equipment on.
4. Select the required function, EI, FL, or OFF, by turning EI / FL / OFF SELECTION SWITCH.

EI (Electronic Iris): The electronic shutter speed varies automatically in accordance with the brightness of an object in a range of 1/60 to 1/100,000 EIA and 1/50 to 1/100,000 CCIR. (The EI function is used in combination with a lens without an iris mechanism.)

FL (Flickerless) : This is effective in reducing flickers on the monitor screen caused by various lighting, such as fluorescent and mercury lamps. (Effective only in areas using 50Hz EIA and 60Hz CCIR.)

OFF : The shutter speed will be fixed at 1/60 EIA or 1/50 CCIR.

Adjustment of the iris is made by turning IRIS LEVEL VOLUME of a DC auto iris lens or lens volume of a video auto iris lens.

5. If there is no picture on the monitor, switch off the power to all equipment and check that the power, video, and any other related terminals are properly connected, and then retry.

Changing the AGC

- The AGC switch must be changed without the AC adaptor and the video cable connected.
- High or low gain can be selected by operating the switch up or down after dismantling the lower housing cover as shown in the drawing.

AGC HI : Selected when sensitivity is a priority.

AGC LO : Selected when S/N ratio is a priority.

- The switch is set to "AGC HI" on shipment.

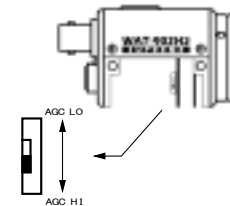

Notes on Back Light Compensation (BLC)

Strong lighting from above or behind an object being monitored causes a silhouetted picture on the monitor. The back light compensation is a function to reduce the darkness of a silhouetted image. With the WAT-902H2/3 SUPREME, this function works constantly. (The drawing on the right shows the dark area targeted by the back light compensation.)

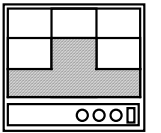

Specifications

Model	WAT-902H2 SUPREME (EIA)	WAT-902H2 SUPREME (CCIR)
Pick-up Element	1/2" interline transfer CCD image sensor	
Total Pixels	811(H) × 508(V)	795(H) × 596(V)
Effective Pixels	768(H) × 494(V)	752(H) × 582(V)
Unit Cell Size	8.4 μm(H) × 9.8 μm(V)	8.6 μm(H) × 8.3 μm(V)
Shutter Speeds	EI : 1/60 - 1/100,000 sec. FL : 1/100 sec. fixed OFF : 1/60 sec. fixed	EI : 1/50 - 1/100,000 sec. FL : 1/120 sec. fixed OFF : 1/50 sec. fixed
Minimum Illumination	0.0003 lx F1.4 (AGC HI)	

Model	WAT-902H3 SUPREME (EIA)	WAT-902H3 SUPREME (CCIR)
Pick-up Element	1/3" interline transfer CCD image sensor	
Total Pixels	811(H) × 508(V)	795(H) × 596(V)
Effective Pixels	768(H) × 494(V)	752(H) × 582(V)
Unit Cell Size	6.35 μm(H) × 7.40 μm(V)	6.50 μm(H) × 6.25 μm(V)
Shutter Speeds	EI : 1/60 - 1/100,000 sec. FL : 1/100 sec. Fixed OFF : 1/60 sec. fixed	EI : 1/50 - 1/100,000 sec. FL : 1/120 sec. fixed OFF : 1/50 sec. fixed
Minimum Illumination	0.0005 lx F1.4 (AGC HI)	

Common Specifications	
Sync. System	Internal
Video Output	1.0Vp-p, 75 (Unbalanced)
Resolution (H)	570TVL (Center)
S/N Ratio	46dB (AGC OFF)
BLC	ON (Center + lower portion measured)
Gamma Characteristic	0.45
Power Supply	DC12V ± 10%
Current	160mA
Operating Temperature	-10 - +40
Storage Temperature	-30 - +70
Dimensions	35.5(W) × 36(H) × 63(L) (mm)
Weight	90g

- Design and specification are subject to change without notice.
- Watec is not responsible for any inconvenience or the attendant damages to the video, audio, and monitoring recording equipment caused by misuse, misoperation, or improper wiring of our equipment.
- If for any reason the camera does not work properly, or if you have any questions regarding installation or operation, please contact the distributor or dealer from which it was purchased.

Dimensions

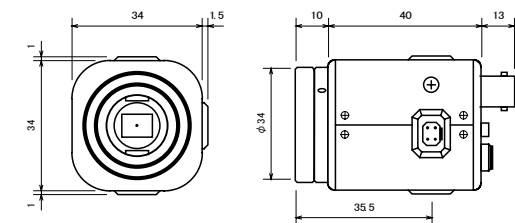

OPT I O N S



AC Adaptor
AD-901

The recommended AC adaptor for the WAT-902H2/3 SUPREME for a constant and stable power supply.



DC Plug
WPDC12

Use this plug if the DC plug of your power adaptor does not fit the WAT-902H2/3 SUPREME.



Auto-iris Plug
AIC-G

Use this connector if the iris connector of your lens does not fit the WAT-902H2/3 SUPREME auto-iris socket.



C-mount Adaptor
30CMA-R

This mount adaptor is used to convert a CS-mount into a C-mount.



Mini-stand
MS-50

A convenient stand for the WAT-902H2/3 SUPREME. With this stand, the camera can be fixed to any desired angle.

Watec Co., Ltd.

254-2 Nihonkoku, Daihoji, Tsuruoka-Shi,
Yamagata-Ken, 997-0017, Japan

TEL: +81-235-25-7164 FAX: +81-235-23-4409

E-mail: Info-o@watec.co.jp

URL: http://www.watec.net